



"Your Direct Source for Condition Monitoring, Test & Measurement"

www.reliabilitydirectstore.com

2911 South Shore Blvd, Suite 170, League City, TX USA 77573 Phone: 281-957-5283 Fax: 281-334-4255



MONARCH INSTRUMENT

Instruction Manual



**Nova-Strobe BB
and
Nova-Strobe BA**
Portable Stroboscopes



Safeguards and Precautions



1. Read and follow all instructions in this manual carefully, and retain this manual for future reference.
2. Do not use this instrument in any manner inconsistent with these operating instructions or under any conditions that exceed the environmental specifications stated.
3. Use of this product may induce an epileptic seizure in persons prone to this type of attack.
4. Objects viewed with this product may appear to be stationary when in fact they are moving at high speeds. Always keep a safe distance from moving machinery and do not touch the target.
5. There are lethal voltages present inside this product. Refer to the section on Lamp Replacement before attempting to open this product.
6. Do not allow liquids or metallic objects to enter the ventilation holes on the stroboscope as this may cause permanent damage and void the warranty.
7. Do not allow cables extending from unit to come into contact with rotating machinery, as serious damage to the equipment, or severe personal injury or death may occur as a result.
8. Do not direct strobe flash toward certain data collectors, as it may temporarily interrupt data collector operation, and could result in loss of stored data.
9. This instrument may not be safe for use in certain hazardous environments, and serious personal injury or death could occur as a result of improper use. Please refer to your facility's safety program for proper precautions.
10. This product contains sealed lead acid batteries which must be disposed of in accordance with Federal, State, & Local Regulations. Do not incinerate. Batteries should be shipped to a reclamation facility for recovery of the metal and plastic components as the proper method of waste management. Contact distributor for appropriate product return procedures.
11. This instrument is not user serviceable. For technical assistance, contact the sales organization from which you purchased the product or Monarch Instrument directly.

LIMITED WARRANTY

SELLER warrants hardware products to be free from any defect in materials or workmanship for a period of one (1) year from date of shipment to BUYER. SELLER's entire liability and BUYER's sole and exclusive remedy resulting from any defect in workmanship or material in the hardware product covered by this limited warranty shall be limited to and fully discharged by the SELLER's option of replacement or repair of such item without charge. The limited warranty provided in this clause is in lieu of all other warranties, expressed or implied, arising by law or otherwise. ALL IMPLIED WARRANTIES OF MERCHANTABILITY AND FITNESS FOR A PARTICULAR PURPOSE ARE EXCLUDED. This limited warranty shall not be modified except by an arrangement signed by both parties specifically referencing this clause.

SELLER warrants that any software supplied will operate in accordance with the documentation or manual supplied therewith in all material respects when used in strict compliance with such documentation or manual. Notwithstanding the foregoing, BUYER acknowledges that, since software is complex and therefore may have defects, BUYER's sole and exclusive remedy for any such defects or breach of this warranty shall be to require SELLER, within a reasonable period of time, to provide all reasonable programming services to correct programming errors in the software. Except as provided above SELLER MAKES AND BUYER RECEIVES FROM SELLER NO EXPRESS OR IMPLIED WARRANTIES OF ANY KIND WITH RESPECT TO ALL OR ANY PORTION OF SOFTWARE AND BUYER HEREBY AGREES AND ACKNOWLEDGES THAT IT ACCEPTS THE SOFTWARE IN 'AS IS' CONDITION. SELLER HEREBY EXPRESSLY EXCLUDES ANY IMPLIED WARRANTIES OF MERCHANTABILITY OR FITNESS FOR A PARTICULAR PURPOSE WITH RESPECT TO THE SOFTWARE. BUYER agrees that any specific right or remedy granted to BUYER hereunder with respect to any breach or default by SELLER shall be in lieu of all other rights and remedies otherwise available to BUYER at law or in equity as the result of such breach or default, regardless of whether based on contract, tort, strict liability, or other theory of liability.

IN NO EVENT SHALL SELLER BE LIABLE FOR ANY SPECIAL, INDIRECT, INCIDENTAL, CONSEQUENTIAL, OR PUNITIVE LOSSES OR DAMAGES (INCLUDING, BUT NOT LIMITED TO, LOSSES OR DAMAGES FOR ANY LOST PROFITS OR LOST DATA) AS THE RESULT OF ANY BREACH OR DEFAULT BY SELLER WITH RESPECT TO THE HARDWARE OR SOFTWARE, EVEN IF SELLER HAS BEEN ADVISED OR MADE AWARE OF THE POSSIBILITY OF ANY SUCH LOSSES OR DAMAGES AND REGARDLESS OF WHETHER THE CLAIM IS BASED ON CONTRACT, TORT, STRICT LIABILITY, OR OTHER THEORY OF LIABILITY.

This limited warranty does not extend or apply to consumables (including, but not limited to, lamps and batteries, if applicable) or equipment, instruments or accessories which are warranted separately by the original manufacturer of these items.

TABLE OF CONTENTS

1.0	SPECIFICATIONS	1
2.0	OVERVIEW	1
2.1	Direct Digital Synthesis	1
2.2	Display Panel	1
3.0	PREPARATION FOR USE	2
3.1	Power	2
4.0	OPERATION	2
5.0	USING THE STROBOSCOPE TO MEASURE RPM	2
6.0	LAMP AND FUSE REPLACEMENT	3
6.1	Lamp Replacement	3
6.2	Fuse Replacement	5
7.0	BATTERY POWERED MODELS ONLY	5
7.1	Low Battery Indication	5
7.2	Charging the Batteries	5
7.3	Battery Disposal	5
8.0	OPTIONS AND ACCESSORIES	6

1.0 SPECIFICATIONS

Flash Range	100 - 8000 FPM (Flashes Per Minute)
Flash Rate Accuracy	± 1 FPM
Flash Rate Resolution	1 FPM
Display Update Rate	Instantaneous
Time Base	Ultra Stable Crystal Oscillator
Display	6-digit alphanumeric LCD display with 0.3 inch [7.62 mm] high digits
Indicators	Low Battery
Knob Adjustment	Digital Rotary switch with 36 detents per revolution; velocity sensitive
Memory	Last setting before power down is remembered and restored on next power up
Input Power	BB - Battery powered: Internal Rechargeable Batteries 6 Vdc, External AC recharger (115 Vac or 230 Vac) BA - AC powered: 115 Vac (BA-115) or 230 Vac (BA-230)
Light Power	Average: 7 W Instantaneous (per flash): 140 mJoule
Flash Duration	25-50 microseconds typical
Weight	Battery powered: 2.5 lbs [1.13 kg] including batteries AC powered: 1.5 lbs [0.68 kg]

2.0 OVERVIEW

All descriptions in this manual apply to both the "Basic" battery powered (BB) and "Basic" AC mains powered (BA) digital stroboscopes except where noted.

The Nova-Strobe Basic models are sophisticated digital instruments with many features yet remain simple to operate. The Strobe's internal microprocessor and digital encoder knob ensure precise settings and measurement. The Strobe "remembers" the previous setting when the power is turned off.

2.1 Direct Digital Synthesis

"Direct Digital Synthesis" is the method by which the Strobe's internal microprocessor generates all the signals required to set internal flash rates. In analog stroboscopes, these values are adjusted using a single or multiple turn potentiometer (knob), which generally lack sensitivity and tend to drift with time. It is very difficult to set absolute values on analog stroboscopes.

The digital strobe synthesizes all signals digitally, in small, very precise steps. These signals are derived from a stable crystal oscillator. There is no user calibration or adjustment required to ensure an accurate reading. These steps are as small as 1 flash per minute. Thus absolute values may be dialed in very easily and accurately. The Strobe's adjustment knob is actually a digital encoder that is connected directly to the microprocessor.

2.2 Display Panel

The display panel consists of a liquid crystal display with six alphanumeric digits, which indicate the flash rate. The battery-powered model will also flash the low battery icon () on the display when the battery is getting low. The display will show "LO BAT" on steady when the strobe must be recharged.

8.0 OPTIONS AND ACCESSORIES

CC-7	Latching carrying case for Strobe with provision for accessories
L-1902	Replacement lamp for BB or BA Strobes
R-5	Slow Recharger 115 Vac 50/60 Hz (14 hour) for battery operated Nova-Strobes
R-6	Same as above, except 230 Vac 50/60 Hz
SPC-1	Splash proof Protective vinyl Cover for Battery Powered Strobe
CAL-N.I.S.T.	N.I.S.T. Traceable Certificate of Calibration

7.0 BATTERY POWERED MODEL ONLY

7.1 Low Battery Indication

When the batteries are low, the low battery icon () blinks on the display once per second. The strobe may still be used for about 5 minutes. When the battery charge is further depleted, the strobe will stop flashing, and "LO BAT" will be displayed until the strobe is shut off. When "LO BAT" is displayed, the unit should be turned off and the batteries must be recharged before the unit will operate again. Do not leave the unit on once "LO BAT" is displayed.

7.2 Charging the Batteries

The batteries may be recharged at any time. You do not need to wait until the low battery condition is indicated.

To charge the battery powered strobe with the recharger:

1. Release the trigger so the strobe is off.
2. Plug the recharger cable into the recharger socket (located below the display panel behind the handle).
3. Plug the recharger into an AC mains wall outlet.

CAUTION: Use of rechargers other than the one supplied (R-5 or R-6) will damage the stroboscope and void the warranty.

The charger will take up to 14 hours to fully charge the batteries. The batteries must be charged to 100% regularly or the batteries will lose capacity.

WARNING: The unit may be left on to charge overnight, but the unit should not be left on charge indefinitely (more than 36 hours) as this will damage the lead acid batteries.

7.3 Battery Disposal

Prior to disposing of the battery-powered strobe, the user must remove the sealed lead acid batteries. To do this, remove the lens, reflector and lamp as detailed in the Lamp Replacement section. This will expose 4 screws that must be removed so the reflector housing can be dismantled. There are four additional screws in the case half opposite the input and output jacks that must be removed. The case halves can now be separated, exposing the batteries. Remove the cables from the batteries and place tape over the battery terminals to prevent them from shorting. The batteries should be sent to a recycling center or returned to the factory. The rest of the parts may now be disposed of.



RECYCLE
Pbs BATTERY

DO NOT
INCINERATE

3.0 PREPARATION FOR USE

The Strobe may be hand held or mounted on a tripod or other user supplied bracket using the ¼-20 UNC bushing at the base of the handle.

3.1 Power

The BA AC powered strobe must have its power cord plugged into an AC outlet (115 Vac or 230 V_{ac}).

The BB battery-powered strobe has internal rechargeable batteries. The unit should be charged before use (see section 7.2). This model can operate continuously in excess of 55 minutes at 6000 flashes per minute from fully charged batteries. The strobe has a protection feature that prevents the strobe from operating if the battery voltage is low. This condition is indicated by no flash and the display show "LO BAT". At this time the batteries must be recharged. The actual operating time of the stroboscope depends on the flash rate and duty cycle of operation. Slower flash rates increase the operating time.

4.0 OPERATION

To turn on the stroboscope, depress and hold the trigger. The trigger may be locked in position using the side-locking button. To do this while holding the unit in the right hand, depress the trigger as far as it will go, and then using the thumb press the locking button. You may release the trigger and the trigger will be held in place. To release, simply depress the trigger and then release.

When the strobe is powered up, it will begin flashing immediately. It will remember the last internal flash rate in FPM.

Turn the knob counter clockwise to increase the flash rate and clockwise to decrease it. The knob is velocity sensitive. Turn the knob slowly to have each "click" is equal to 1 FPM. Turning the knob more quickly will adjust the FPM by larger steps. When adjusting flash rate, quickly turn the knob to coarsely change the FPM. Then slowly turn the knob for fine adjustments. Turn slower still for very fine adjustments.

5.0 USING THE STROBOSCOPE TO MEASURE RPM

The primary use for a stroboscope is to stop motion for diagnostic inspection purposes. However the stroboscope can be used to measure speed. In order to do this, several factors need to be considered. First, the object being measured should be visible for all 360° of rotation (e.g. The end of a shaft). Second, the object should have some unique part on it, like a bolt, key way or imperfection to use as a single reference point. If the object being viewed is perfectly symmetrical, then the user needs to mark the object with a piece of tape or paint in a single location to be used as a reference point. Look only at the reference point.

If the speed of rotation is within the range of the stroboscope, start at the highest flash rate and adjust the flash rate down. At some point you will stop the motion with only a single image of the reference point (object) in view. Note that at a flash rate twice the actual speed of the image you will see two images. As you approach the correct speed you may see three, four or more images at harmonics of the actual speed. The first SINGLE reference point you see is the true speed. To confirm the true speed, note the reading and adjust the stroboscope to exactly half this reading. You should again see a single reference point (which may be phase shifted with respect to the first image seen).

For example, when viewing a shaft with a single key way you will see one stationary image of the key way at the actual speed and at 1/2, 1/3, 1/4, etc., of the actual speed. You will see 2 images of the key way at 2 times the actual speed, 3 key way at 3 times, etc. The FPM equals the shaft's Revolutions Per Minute (RPM) at the highest flash rate that gives only one stationary image of the key way.

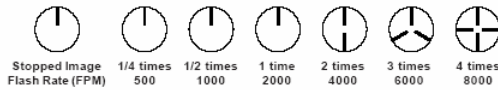

Figure 1 Object Rotating at 2000 FPM

If the speed is outside the full scale range of the stroboscope (8,000 FPM), it can be measured using the method of harmonics and multipoint calculation. Start at the highest flash rate and adjust the flash rate down. You will encounter multiple images so be aware of these. Note the flash rate of the first SINGLE image you encounter, call this speed "A". Continue decreasing the flash rate until you encounter a second SINGLE image. Note this speed as "B". Continue decreasing the speed until you reach a third SINGLE image at speed "C".

For a two point calculation the actual speed is given by:

$$RPM = AB / (A - B)$$

For a three point calculation:

$$RPM = 2XY(X+Y) / (X-Y)^2 \text{ where}$$

$$X = (A - B) \text{ and}$$

$$Y = (B - C)$$

In instances when you can shut down the device and install a piece of reflective tape, then an optical tachometer is easier to use for RPM measurement. Stroboscopes must be used when you can't shut down the device. The human eye is not easily tricked into seeing a stopped image by a stroboscope when the flash rate is slower than 300 FPM. Therefore, stroboscopes are just about impossible to use below 300 FPM for inspection or to measure RPM.

6.0 LAMP AND FUSE REPLACEMENT

6.1 Lamp Replacement (L-1902)

WARNING: Before attempting to remove the lamp, make sure the stroboscope is turned off and any mains cord removed from the ac outlet. Allow the lamp to cool, waiting at least 1 minute.



The stroboscope is designed to discharge the internal high voltages within 30 seconds. However, caution should be exercised when replacing the lamp.

The lamp can be replaced by using only a pocket screwdriver. It is not necessary to remove any screws to replace the lamp. A spare lamp is supplied with each new BB and BA Strobe Kit or can be ordered separately.

To change the lamp:

1. Push apart the two tabs on the side of the reflector housing and remove the front lens using a small screwdriver to help pry one tab and lift the lens. Take care not to pry the tab any more than is necessary to free the lens. The reflector is held in place by the front lens and will come loose, but is not necessary to remove the reflector.

3

2. Hold the lamp with a cloth between your forefinger and thumb and rock it back and forth gently while pulling out. Do not attempt to rotate the lamp. The lamp is socketed and will come out easily when pulled.

WARNING: Do NOT touch the new lamp with bare fingers.

3. The lamps are polarized and must be put into the socket matching polarity. Using a lint free cloth, match up the red dot on the plug with the red dot on the socket and gently rock the lamp back and forth while pushing it into place (see Figure 2). Make sure the lamp is in straight and centered in the reflector hole.

CAUTION: Do NOT allow the reflector to contact the lamp.

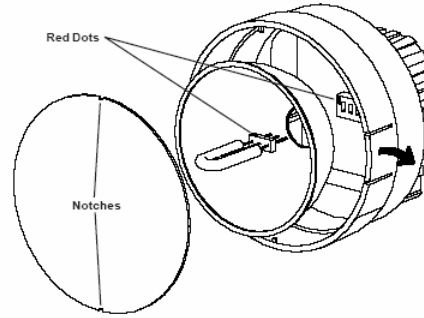

Figure 2 Lamp Replacement

4. Reinstall the reflector and then position the front lens in place matching up the notches on the lens with the two small tabs on the housing to prevent lens rotation (see Figure 2). Push the tabs on the front rim outward and press the lens into place.

6.2 Fuse Replacement

There is a fuse inside the unit which may be accessed by removing the lens and reflector (refer to section 6.1). Under normal operating conditions, the fuse should never blow. Examples of abnormal operating conditions would be foreign materials entering the strobe, such as water, ink, etc. If the fuse needs to be replaced, replace only with a fuse of the same type and value:

BB - Battery Powered: Slow Blow - 2.5A, 5x20 mm fuse (part# 1062-3004-008)

BA - AC Powered: Fast Blow - 750mA, 2AG fuse (part# 1062-0201-001)

4